SP 3300 LI ▪ SP 3500 LI ▪ SP 3800 LI

The pumps listed on this data sheet represent a cross-section of the large number of possibilities for each pump type. Based on our modular pump design, all pumps can be customised exactly to meet the needs of your application - within days and at standard pricing. Please contact us for details.



SP 3300 LI-D / LI-DV
SP 3500 LI-D / LI-DV
SP 3800 LI-D / LI-DV

Product Features

- Flat casing
- High flow
- Durable design
- Oil-free, maintenance-free, leak-tight
- Low vibration and sound level

Typical Applications

- Battery chargers
- Pressure and vacuum supply

SP 3300 LI ▪ SP 3500 LI ▪ SP 3800 LI

TYPE	SP 3300 LI-D	SP 3300 LI-DV	SP 3500 LI-D	SP 3500 LI-DV	SP 3800 LI-D	SP 3800 LI-DV
Operating Voltage [Vac]	230	230	230	230	230	230
Frequency [Hz]	50	50	50	50	50	50
Art. No.	7s77025	7s77000	7s77026	7s77001	7s77027	7s77002
Power Consumption [W]	12	12	15	15	24	24
PERFORMANCE						
max. Flow [l/min]	14,7	14,7	15,0	15,0	20,8	20,8
max. Pressure [bar]	0,15	0,15	0,21	0,21	0,27	0,27
max. Vacuum [mbar]	-	-150	-	-160	-	-240
MOTOR						
Standard Motor	linear					
Motor Connection	2 wires					
Optional Motor	n/a					
MATERIALS						
Standard Pump Head	PA6 & PA66					
Optional Pump Head	n/a					
Standard Diaphragm	EPDM					
Optional Diaphragm	n/a					
Standard Valves	EPDM					
Optional Valves	n/a					
Standard Gaskets	CR-SBR & NBR					
Optional Gaskets	n/a					
PNEUMATIC CONNECTION						
Standard Connectors	straight connectors					
Optional Connectors	n/a					
DIMENSIONS + WEIGHT						
Dimensions [mm] W x H x L	122 x 58,5 x 128					
Weight [g]	950					

Flow values are subject to the standard conditions specified in DIN 1343. The use of other materials may cause deviations in performance values.

The technical data shown on this data sheet represents the typical mean values achieved by the products in our standard testing procedure.

All data provided is for information only and does not represent production values.

Standard products are subject to change without notice.

26.05.2021

SP 3300 LI ▪ SP 3500 LI ▪ SP 3800 LI

PERFORMANCE DIAGRAM | SP 3300 LI ▪ SP 3500 LI ▪ SP 3800 LI

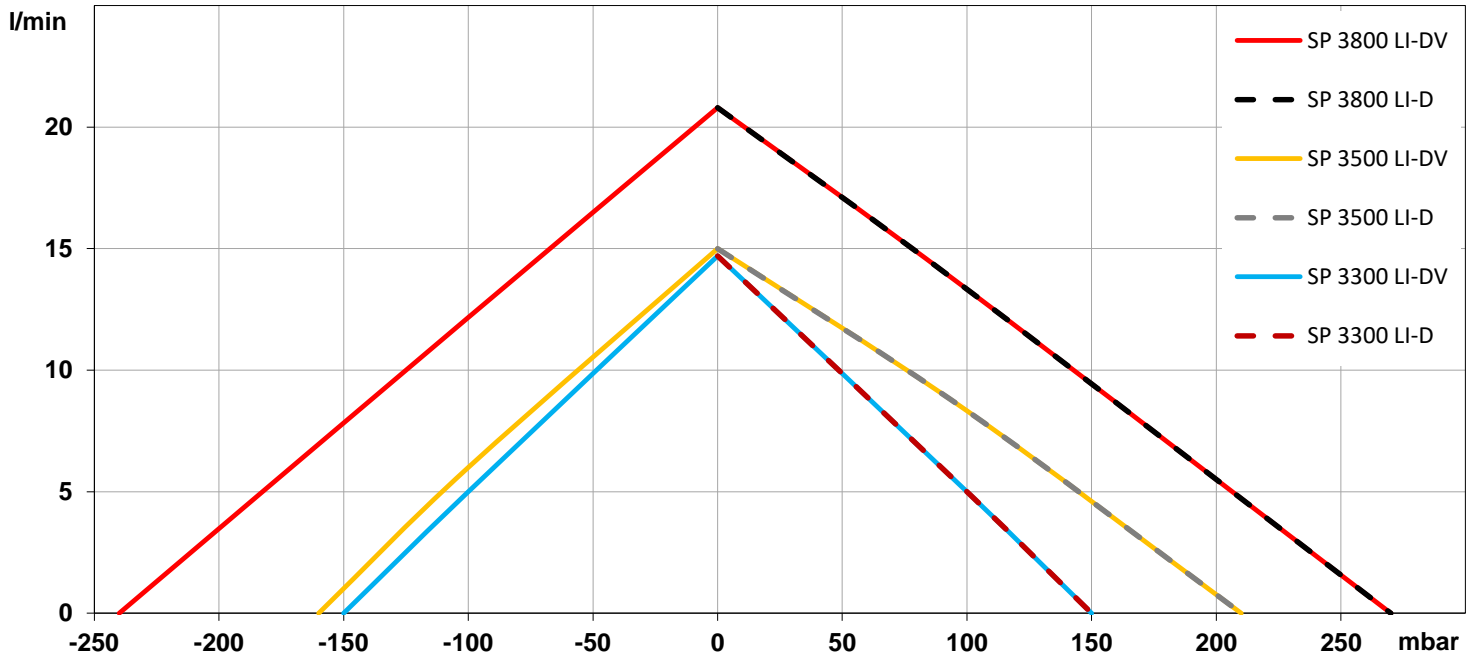

DRAWING | SP 3300 LI ▪ SP 3500 LI ▪ SP 3800 LI

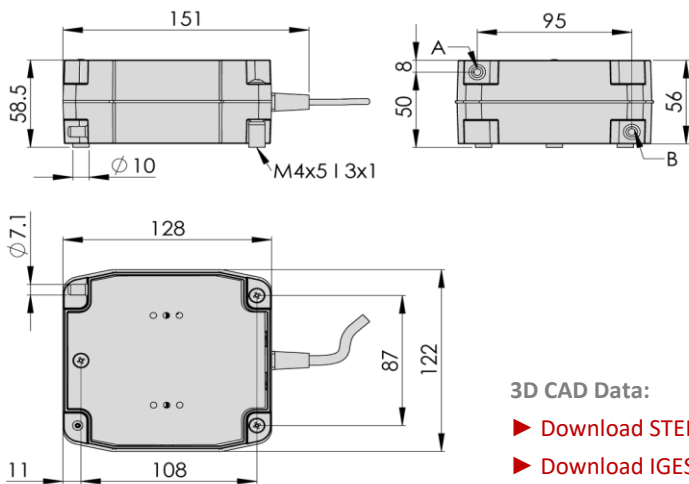

All data provided is for information only and does not represent production values.
Standard products are subject to change without notice.

26.05.2021